

## 6000PLUS/OPHTCO/SVAD Optical Smoke Heat & CO Sensor Plus Sounder and Visual Alarm Device

- Multiple Technology Sensor
- Combined Smoke, Heat and Carbon Monoxide Sensors
- Integrated Electronic Sounder
- Integrated EN54-23 Visual Alarm Device
- Loop Powered
- Low Current
- Programmable Volume Control
- Integral Short Circuit Isolator
- Protec Algo-Tec™ 6000PLUS Protocol
- Devices Display Address Number
- FAST™ Addressing
- Unprecedented False Alarm Rejection
- VAD Classification Adjustable from 3m to 7.5m Room Coverage Volume



The Protec Algo-Tec™ 6000PLUS sensor range have been developed to incorporate advanced fire sensing technology, electronic sounders, high intensity LED visual alarm devices (VAD) and speech enhanced talking sounder capability, all integrated within the sensor head and powered from the loop.

**6000PLUS/OPHTCO/SVAD** Interactive addressable high performance optical smoke, heat and carbon monoxide multi-sensor.

The ultimate in multi-sensor technology, providing a formidable weapon in the pursuit of reliable fire detection and the avoidance of unwanted or false alarms. The sensor provides total confidence that when initiated, there really is a fire threat. The sensor incorporates infra-red light scattering for smoke detection, with thermal enhancement of the optical sensitivity, temperature detection equivalent to grade A2, and a third channel incorporating a carbon monoxide (CO) sensing element. The combination of optical smoke, heat and carbon monoxide gas sensing technology within one fire detector head provides the ideal solution. The sensor can now detect free burning chemical fires, fires

producing smoke and low levels of CO and heat, to deep seated smouldering fires, which produce little heat and smoke but large amounts of CO.

Combining the results from all sensing channels enables rapid fire detection with rejection of false alarms and increased sensor reliability.

**Sensor Sounder** - The Protec Algo-Tec™ 6000PLUS/OPHTCO/SVAD sensor is equipped with an integrated loop powered electronic sounder with three programmable sounder tone options, constant, pulse or warble selectable by the control panel along with adjustable volume control. A loop short circuit isolator is also incorporated within the head. The sensor sounder tones are compatible with the full range of Protec 6000 electronic sounders.

**Sensor VAD** - Compliance with DDA legislation is assisted by the addition of the Protec visual alarm device (VAD) to the 6000PLUS sensor, to warn those with hearing impairments or in noisy environments. The VAD utilises a high intensity LED with lower power consumption and increased reliability when compared to alternative indicators.

# 6000PLUS/OPHTCO/SVAD Technical Specification



### Dimensions (mm)

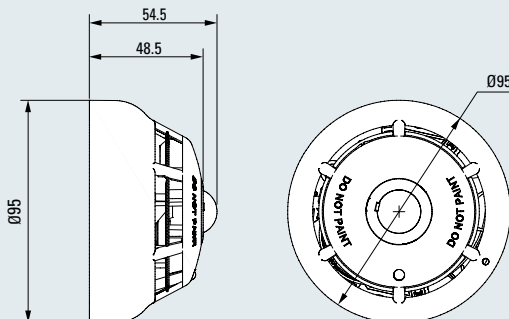

### Typical Wiring using 6000PLUS/BASE

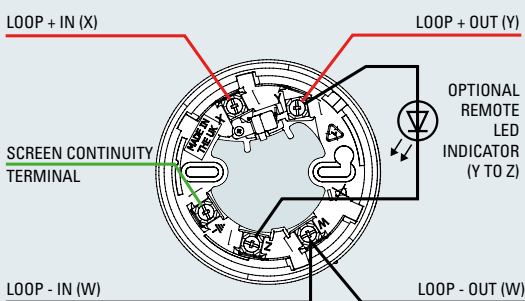

### Technical Specification:

Environment	-10°C to +50°C (95% R.H. non condensing)
Ingress Protection	IP21C
Weight (excluding base)	105g
Loop Powered	Yes
Loop Voltage	18 - 28V
Loop Standby Load	0.55mA
Peak Alarm Load	24mA
Mounting Height	3m
Coverage	7.5m, 5m or 3m cylindrical diameter
VAD Flash Rate	1Hz to 0.5Hz white flash
Isolator	Yes
Device Protocol	Algo-Tec™ 6000PLUS
Product Approval	CoCP No: 0356-CPR-0407 DoP No: PFD-CPR-0091 Relevant Standard: EN54 Part 3, 5, 7, 17 & 23 AS7240 Part 15 (5&7) & 23



### Sensor VAD Continued...

The VAD is located in the centre of the sensor, so can be viewed from all angles. Suitable for ceiling mounting the VAD distributes light in a cylindrical pattern to achieve the required minimum illumination of 0.4lux over the entire coverage area in accordance with EN54-23.

The maximum mounting height is 3m with a coverage diameter of 7.5m.

For smaller areas the device can be programmed on-site for coverage diameter of 3m or 5m at reduced power.

### Tone Options

Warble Tone: 990Hz(250ms), 730Hz(250ms)  
Continuous Tone: 990Hz  
Pulse Tone: 990Hz(500ms), Silence(500ms)

### Tone Volume Options

The tone and volume are selectable at the control panel (measured at one metre):  
High: 85dB(A), Mid: 75dB(A), Low: 65dB(A)

### Design Guidance

Protec VAD's have been approved to BS EN 54-23 and use the rating codes below:

### C-x-y (eg C-3-7.5)

Where:

- C** is Ceiling Mounted
- x** is the Maximum Height (M)
- y** is the illumination diameter for the cylindrical volume (M)

BS EN 54-23 approved VAD's are approved as Ceiling mounted and must provide a minimum illumination level of 0.4 lux for the stated volume

### Table A: Direct Viewing

Coverage volumes for various ambient light levels (lux)

BS EN54-23 Rating	C-3-7.5
Mounting Position	Ceiling
Less than 100 lux	21dia
100 - 200 lux	18dia
200 - 300 lux	14.3dia
300 - 400 lux	10.5dia
400 - 500 lux	8.3dia
500 - 600 lux	6.8dia
600 - 700 lux	5.3dia
700 - 800 lux	3.8dia

### Table B: Indirect Viewing

Coverage volumes for various ambient light levels (lux)

BS EN54-23 Rating	C-3-7.5
Mounting Position	Ceiling
Less than 100 lux	9.8dia
100 - 200 lux	9dia
200 - 300 lux	7.5dia
300 - 400 lux	6dia
400 - 500 lux	4.5dia
500 - 600 lux	3.8dia
600 - 700 lux	*
700 - 800 lux	*

Coverage volumes height, diameter, length and width dimensions are in metres.

\* Where ambient light levels may, at any time, exceed 600 lux, direct viewing is preferred (CoP 001 clause 4.6.9.4)

